

Motor Rating	3-Phase 200V	3-Phase 400V
0.75 kW	LSLV0008H100-2CONN	LSLV0008H100-4COFN
1.5 kW	LSLV0015H100-2CONN	LSLV0015H100-4COFN
2.2 kW	LSLV0022H100-2CONN	LSLV0022H100-4COFN
3.7 kW	LSLV0037H100-2CONN	LSLV0037H100-4COFN
5.5 kW	LSLV0055H100-2CONN	LSLV0055H100-4COFN
7.5 kW	LSLV0075H100-2CONN	LSLV0075H100-4COFN
11 kW	LSLV0110H100-2CONN	LSLV0110H100-4COFN
15 kW	LSLV0150H100-2CONN	LSLV0150H100-4COFN
18.5 kW	LSLV0185H100-2CONN	LSLV0185H100-4COFN
22 kW		LSLV0220H100-4COFN
30 kW		LSLV0300H100-4COFN
37 kW		LSLV0370H100-4COND
45 kW		LSLV0450H100-4COND
55 kW		LSLV0550H100-4COND
75 kW		LSLV0750H100-4COFD
90 kW		LSLV0900H100-4COFD
110 kW		LSLV1100H100-4COFD
132 kW		LSLV1320H100-4COFD
160 kW		LSLV1600H100-4COFD
185 kW		LSLV1850H100-4COFD
220 kW		LSLV2200H100-4COFD
250 kW		LSLV2500H100-4COFD
315 kW		LSLV3150H100-4COFD
355 kW		LSLV3550H100-4COFD
400 kW		LSLV4000H100-4COFD
500 kW		LSLV5000H100-4COFD

※75-90kW satisfies EMC class 3

LSLV0055H100-4COFN		Model Name
INPUT	380-480V 3Phase 50/60Hz 12.2A	Power Source Specifications
OUTPUT	0-Input V 12A 9.1kVA Ser. No 55025310146 Inspected by D. K. YU MSIP-REM-LSR-XXXXXXX	Output Specifications
		
LS		Made in Korea



LSLV	0055	H100	-	4	C	O	F	N
Series Name				Input Voltage	Keypad Type	UL Type	EMC Filter	Reactor
Motor Capacity				2: 3-phase 200-240V 4: 3-phase 380-480V	C: LCD Keypad	O: UL Open E: UL Type1	F: Built-in EMC N: Non EMC	D: Built in DC Reactor N: Non DC Reactor
0008-0.75kW	0150-15kW	0750-75kW	2500-250kW					
0015-1.5kW	0185-18.5kW	0900-90kW	3150-315kW					
0022-2.2kW	0220-22kW	1100-110kW	3550-355kW					
0037-3.7kW	0300-30kW	1320-132kW	4000-400kW					
0055-5.5kW	0370-37kW	1600-160kW	5000-500kW					
0075-7.5kW	0450-45kW	1850-185kW						
0110-11kW	0550-55kW	2200-220kW						

3-Phase 200V (0.75~18.5kW)

Model Name LSLV□□□□H100-2□□□□		0008	0015	0022	0037	0055	0075	0110	0150	0185
Applied Motor	HP	1.0	2.0	3.0	5.0	7.5	10	15	20	25
	kW	0.75	1.5	2.2	3.7	5.5	7.5	11	15	18.5
Output Rating	Rated Capacity (kVA)	1.9	3.0	4.5	6.1	8.4	11.4	16.0	21.3	26.3
	Rated Current	5	8	12	16	22	30	42	56	69
	Output Frequency	0~400Hz								
	Output Voltage (V)	3-Phase 200~240V								
Input Rating	Service Voltage (V)	3-Phase 200~240VAC (-15%~+10%)								
	Input Frequency	50~60Hz(5%)								
	Rated Current (A)	4.9	8.4	12.9	17.5	23.7	32.7	46.4	62.3	77.2
Weight (kg)		3.3	3.3	3.3	3.3	3.3	3.3	3.3	4.6	7.1

3-Phase 400V (0.75~22kW)

Model Name LSLV□□□□H100-4□□□□		0008	0015	0022	0037	0055	0075	0110	0150	0185	0220
Applied Motor	HP	1.0	2.0	3.0	5.0	7.5	10	15	20	25	30
	kW	0.75	1.5	2.2	3.7	5.5	7.5	11	15	18.5	22
Output Rating	Rated Capacity (kVA)	1.9	3.0	4.5	6.1	9.1	12.2	18.3	23.0	29.0	34.3
	Rated Current	2.5	4	6	8	12	16	24	30	38	45
	Output Frequency	0~400Hz									
	Output Voltage (V)	3-Phase 380~480V									
Input Rating	Service Voltage (V)	3-Phase 380~480VAC (-15%~+10%)									
	Input Frequency	50~60Hz(5%)									
	Rated Current (A)	2.4	4.2	6.5	8.7	12.2	17.5	26.5	33.4	42.5	50.7
Weight (kg)		3.3	3.3	3.3	3.3	3.3	3.3	3.4	4.6	4.8	7.5

3-Phase 400V (30~90kW)

Model Name LSLV□□□□H100-4□□□□		0300	0370	0450	0550	0750	0900
Applied Motor	HP	40	50	60	75	100	125
	kW	30	37	45	55	75	90
Output Rating	Rated Capacity (kVA)	46.5	57.1	69.4	82.0	108.2	128.8
	Rated Current	61	75	91	107	142	169
	Output Frequency	0~400Hz					
	Output Voltage (V)	3-Phase 380~480V					
Input Rating	Service Voltage (V)	3-Phase 380~480VAC(-15%~+10%)					
	Input Frequency	50~60Hz(±5%)					
	Rated Current (A)	69.1	69.3	84.6	100.1	133.6	160.0
Weight (kg) / EMC Built-in	7.5	26	35	35	43		
Weight (kg) / Non EMC	-	25	34	34			

3-Phase 400V (110~500kW)

Model Name LSLV□□□□H100-4□□□□		1100	1320	1600	1850	2200	2500	3150	3550	4000	5000
Applied Motor	HP	150	200	250	300	350	400	500	550	650	800
	kW	110	132	160	185	220	250	315	355	400	500
Output Rating	Rated Capacity (kVA)	170	201	248	282	329	367	467	520	587	733
	Rated Current	223	264	325	370	432	481	613	683	770	962
	Output Frequency	0~400Hz									
	Output Voltage (V)	3-Phase 380~500V									
Input Rating	Service Voltage (V)	3-Phase 380~500VAC(-15%~+10%)									
	Input Frequency	50~60Hz(±5%)									
	Rated Current (A)	215.1	254.6	315.3	358.9	419.1	469.3	598.1	666.4	751.3	938.6
Weight (kg)	55.8	55.8	74.7	74.7	120.0	120.0	185.5	185.5	185.5	265	

- Motor capacity is based on use of 4-pole standard motors.
- 200V Class is for 220V and 400V Class is for 440V.
- Rated output current is limited depending on the carrier frequency (CON-04) setting.
- 400V 0.75~30kW, 110~500kW, EMC filter is built-in as default. [C3]
- 400V 37~55kW, EMC filter is provided as built-in product option. [C3]
- 400V 75~90kW, products satisfy EMC specifications even without a filter.

Item		Description		
Control	Control Mode	V/F control, slip compensation		
	Frequency Set Resolution	Digital command: 0.01Hz Analog command: 0.06Hz (based on 60Hz)		
	Control Degree of Frequency	1% of the maximum output frequency		
	V/F Pattern	Linear, squared overload reduction and user V/F		
	Overload Capacity	0.75~90kW	Rated Current: 120% 1 minute	
		110~500kW	Rated Current: 110% 1 minute	
Torque Boost	Manual torque boost, Automatic torque boost			
Control (Operation)	Drive Mode	Optional: Keypad, terminal board or communication control		
	Frequency Setting	Analog mode: -10~10V, 0~10V, 0~20mA Digital mode: Keypad and pulse train input		
	Control Functions	PID control, 3-Wire control, Frequency limitation, Secondary Functions, Forward/Reverse rotation prohibited, DC braking, Commercial power switching, Speed search, Power braking, Reduction of leakage, Up-Down control, DC braking Flux braking, Frequency pump, Slip compensation, Automatic restart, Automatic tuning, Energy buffering control, Energy-saving control		
	Input	Multifunctional Terminal (7 points)	The following functions can be set using IN-65~71 code parameters between PNP(Source) and NPN(Sink). Forward Operation, Reset, Emergency stop, Multi-step frequency – High/Mid/Low, DC braking during stop, Pre-Heat, Frequency increase, 3-Wire, Optional: Acceleration, deceleration or stop, MMC interlock, Reverse Operation, Pump cleaning, External trip, Jog control, Multi-step acceleration/deceleration-High/Mid/Low, Secondary motor selection, RTC(Time event function), Frequency decrease, Analog command frequency fixation, Switching to normal operation during PID operation,	
		Pulse Train	0~32kHz, Low Level: 0~0.8V, High Level: 3.5~12V	
	Output	Multifunctional Open Collector Terminal	Failure output & drive control status output:	DC 26V, 50mA or below
		Failure (Fault) Relay Terminal		N.O. : AC 250V, 2A or below, DC30V, 3A or below N.C. : AC 250V, 1A or below, DC30V, 1A or below
		Multifunctional Relay Terminal		AC250V, 5A or below, DC30V, 5A or below
		Analog Output		0~12Vdc(0~20mA): Optional among frequency, output current, output voltage and DC voltage.
	Pulse Train	Maximum 32kHz, 0~12V		
Protective Functions	Trip	Over-current trip, Trip caused by external signals, ARM short-circuit current trip, Overheat trip, Pipe broken trip, Input open-phase trip Ground trip, Motor overheat trip, IO board connection trip, No Motor trip, Parameter Write trip, Emergency stop trip, Command loss trip, External memory error, CPU watchdog trip, Motor under-load trip, Overvoltage trip, Temperature sensor trip, Drive overheat, Option trip, Output open-phase trip, Drive overload trip, Fan trip, Low voltage trip during operation, Low voltage trip, Analog input error, Motor overload trip, Keypad command loss trip, Damper trip, Level Detect trip, All auxiliary motor failure trip, Pump clean failure (fault)		
	Warning	Command loss trip warning, overload warning, under-load warning, drive overload warning, fan operation warning, damping resistance brake percentage warning, capacitor life warning, pump clean warning, Fire Mode warning and LDT warning		
	Instant Power Interruption	Below 8 ms: Continuous operation (within the rated input voltage and rated output) 8 ms or above: Automatic restart operation		
Structure/Operational Environment	Cooling mode	Forced air-cooling		
	Protective structure	IP20/UL Open(default), UL Enclosed Type 1(option)		
	Ambient temperature	With no ice or frost at -10~50°C(14~122°F) [At 40°C or above, derating of 2.5%/1°C current. At 50°C, 75% of the rated current is operable].		
	Ambient humidity	Relative humidity of 95% RH or below (without dew formation)		
	Storage temperature	-20 ~ 65 °C (-4~149°F)		
	Ambient environment	Without corrosive gas, combustible gas, sludge and dust (Pollution Degree 3 Environment)		
	Altitude	Maximum 1000m above sea level for standard operation. From 1000 to 4000m, the rated input voltage and rated output current of the drive must be derated by 1% for every 100m.		
	Vibration	9.8m/sec ² (1.0G) or below		
Ambient atmospheric pressure	70~106kPa			

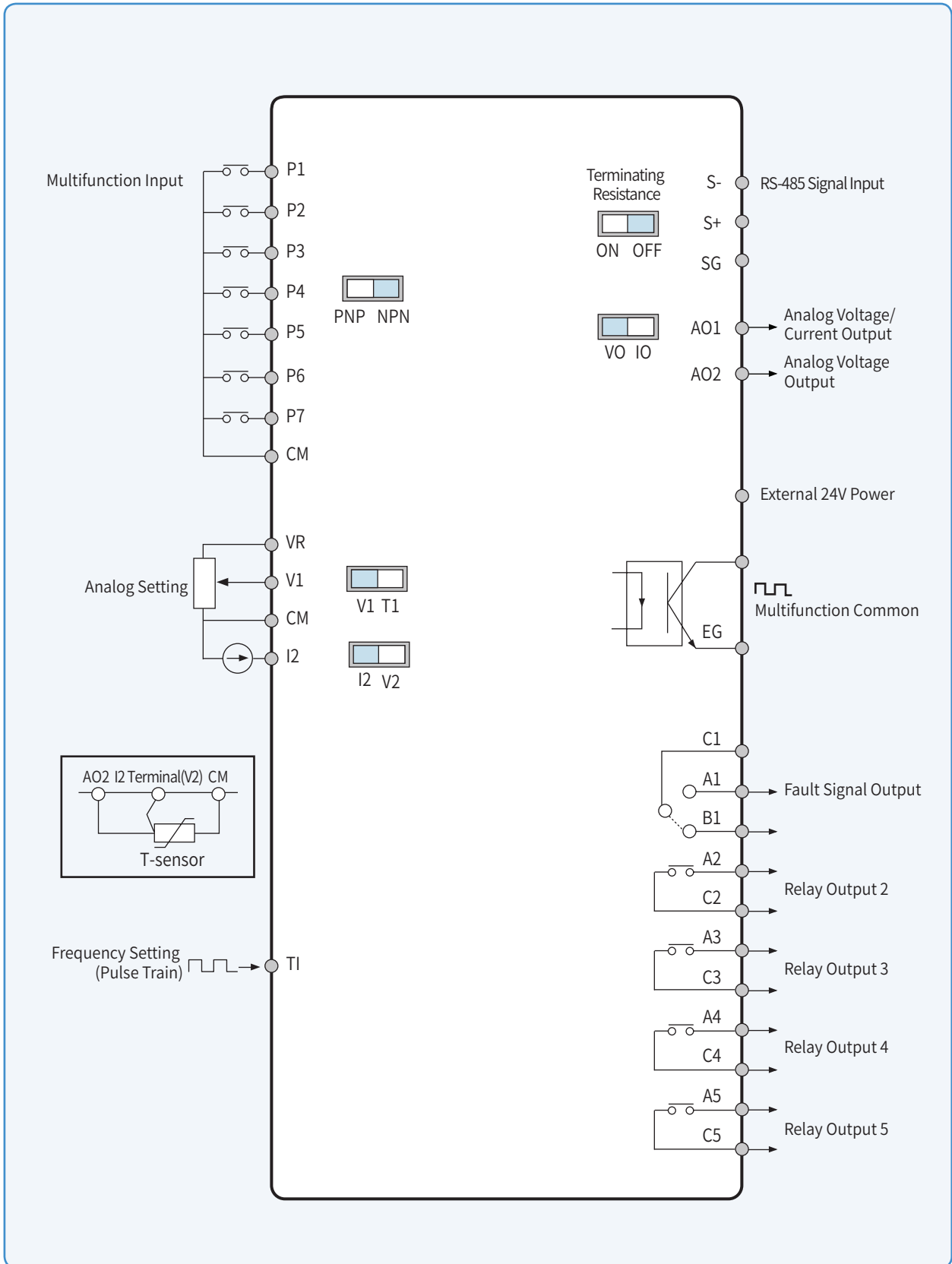

※The default value is displayed in blue color

Power Terminal Marks & Details

0.75~30kW(3-Phase)

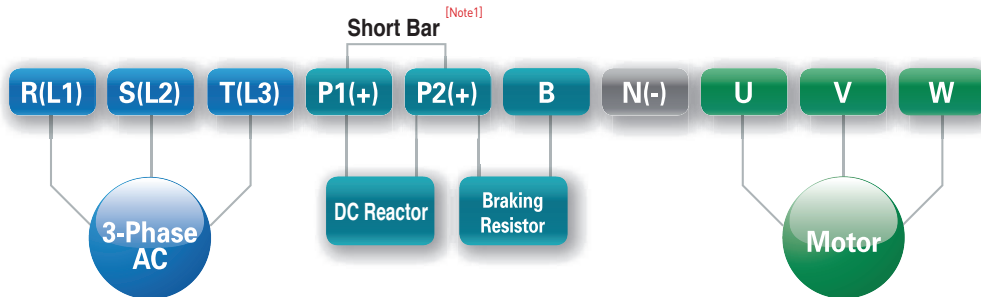

Terminal Mark	Name	Description
R(L1) / S(L2) / T(L3)	AC power input terminal	Mains supply AC power connections.
P1(+) / P2(+)	DC reactor terminal	DC Reactor wiring connection. (When you use the DC Reactor, must remove shortbar.)
P2(+) / N(-)	DC link terminal	DC voltage terminals.
P2(+) / B	Braking resistor terminal	Braking resistor wiring connection.
U / V / W	Motor output terminal	3-phase induction motor wiring connections.

Note 1) Short Bar should be removed when wiring DC Reactor.

37~90kW(3-Phase)

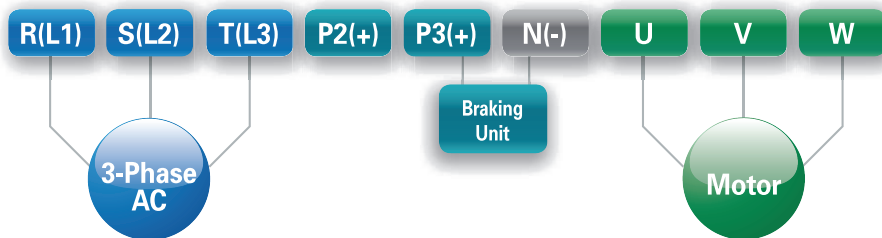

Terminal Mark	Name	Description
R(L1) / S(L2) / T(L3)	AC power input terminal	Mains supply AC power connections.
P2(+) / N(-)	DC link terminal	DC voltage terminals.
P3(+) / N(-)	Brake unit terminal	Brake unit wiring connection.
U / V / W	Motor output terminal	3-phase induction motor wiring connections.

Power Terminal Marks & Details

110–250kW (3-Phase)

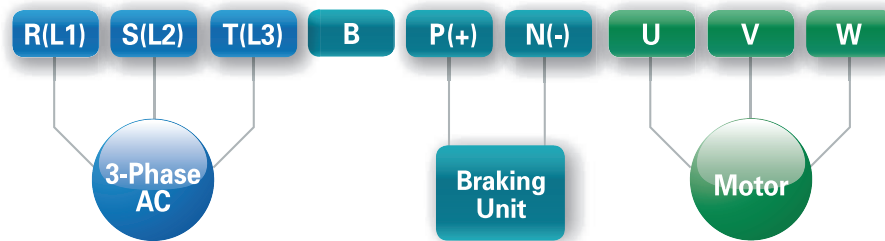

Terminal Mark	Name	Description
R(L1) / S(L2) / T(L3)	AC power input terminal	Mains supply AC power connections.
B	-	It can not be used.
P(+)/ N(-)	DC link terminal (or Brake unit terminal)	Connect to DC voltage terminal. (or Brake unit wiring connection)
U / V / W	Motor output terminal	3-phase induction motor wiring connections.

315–500kW (3-Phase)

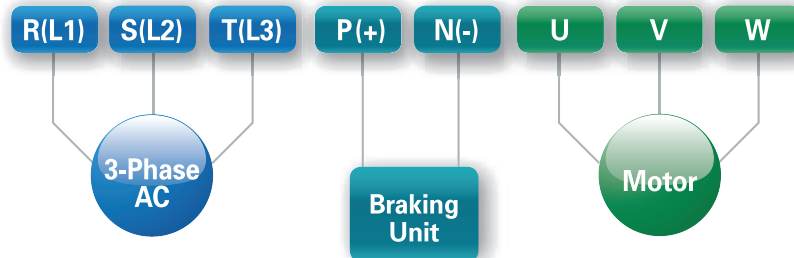

Terminal Mark	Name	Description
R(L1) / S(L2) / T(L3)	AC power input terminal	Mains supply AC power connections.
P(+)/ N(-)	DC link terminal (or Brake unit terminal)	Connect to DC voltage terminal (or Brake unit wiring connection)
U / V / W	Motor output terminal	3-phase induction motor wiring connections.

IP 20 Type

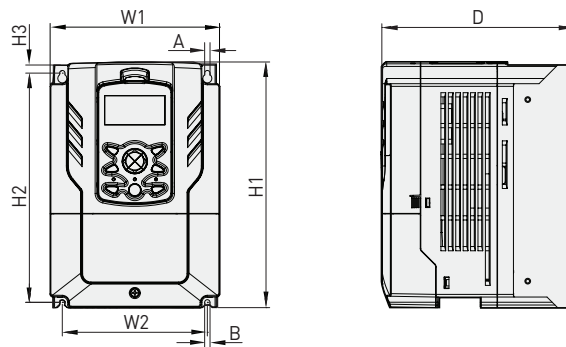

Unit:mm(inches)

Product (Model)		W1	W2	H1	H2	H3	D	A	B	kg
3-Phase 200V	LSLV0008H100-2	160(6.30)	137(5.39)	232(9.13)	216.5(8.52)	10.5(0.41)	181(7.13)	5(0.20)	5(0.20)	3.3
	LSLV0015H100-2	160(6.30)	137(5.39)	232(9.13)	216.5(8.52)	10.5(0.41)	181(7.13)	5(0.20)	5(0.20)	3.3
	LSLV0022H100-2	160(6.30)	137(5.39)	232(9.13)	216.5(8.52)	10.5(0.41)	181(7.13)	5(0.20)	5(0.20)	3.3
	LSLV0037H100-2	160(6.30)	137(5.39)	232(9.13)	216.5(8.52)	10.5(0.41)	181(7.13)	5(0.20)	5(0.20)	3.3
	LSLV0055H100-2	160(6.30)	137(5.39)	232(9.13)	216.5(8.52)	10.5(0.41)	181(7.13)	5(0.20)	5(0.20)	3.3
	LSLV0075H100-2	160(6.30)	137(5.39)	232(9.13)	216.5(8.52)	10.5(0.41)	181(7.13)	5(0.20)	5(0.20)	3.3
	LSLV0110H100-2	160(6.30)	137(5.39)	232(9.13)	216.5(8.52)	10.5(0.41)	181(7.13)	5(0.20)	5(0.20)	3.3
3-Phase 400V	LSLV0008H100-2	160(6.30)	137(5.39)	232(9.13)	216.5(8.52)	10.5(0.41)	181(7.13)	5(0.20)	5(0.20)	3.3
	LSLV0015H100-2	160(6.30)	137(5.39)	232(9.13)	216.5(8.52)	10.5(0.41)	181(7.13)	5(0.20)	5(0.20)	3.3
	LSLV0022H100-2	160(6.30)	137(5.39)	232(9.13)	216.5(8.52)	10.5(0.41)	181(7.13)	5(0.20)	5(0.20)	3.3
	LSLV0037H100-2	160(6.30)	137(5.39)	232(9.13)	216.5(8.52)	10.5(0.41)	181(7.13)	5(0.20)	5(0.20)	3.3
	LSLV0055H100-4	160(6.30)	137(5.39)	232(9.13)	216.5(8.52)	10.5(0.41)	181(7.13)	5(0.20)	5(0.20)	3.3
	LSLV0075H100-4	160(6.30)	137(5.39)	232(9.13)	216.5(8.52)	10.5(0.41)	181(7.13)	5(0.20)	5(0.20)	3.3
	LSLV0110H100-4	160(6.30)	137(5.39)	232(9.13)	216.5(8.52)	10.5(0.41)	181(7.13)	5(0.20)	5(0.20)	3.3

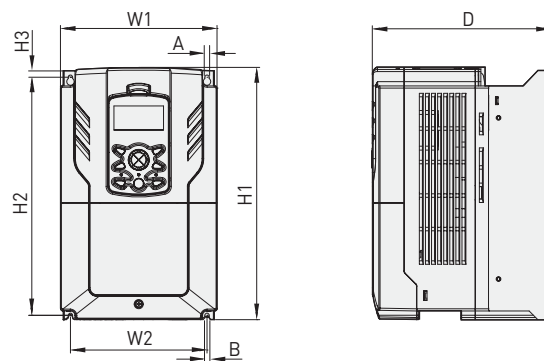

Unit:mm(inches)

Product (Model)		W1	W2	H1	H2	H3	D	A	B	kg
3-Phase 200V	LSLV0150H100-2	180(7.09)	157(6.18)	290(44.42)	273.7(10.78)	11.3(0.45)	205.3(8.08)	5(0.20)	5(0.20)	4.6
3-Phase 400V	LSLV0150H100-4	180(7.09)	157(6.18)	290(44.42)	273.7(10.78)	11.3(0.45)	205.3(8.08)	5(0.20)	5(0.20)	4.6
	LSLV0185H100-4	180(7.09)	157(6.18)	290(44.42)	273.7(10.78)	11.3(0.45)	205.3(8.08)	5(0.20)	5(0.20)	4.8

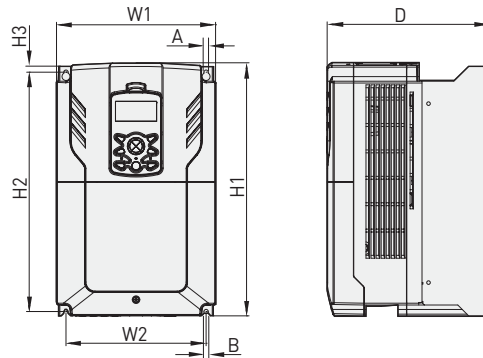

Unit: mm(inches)

Product (Model)		W1	W2	H1	H2	H3	D	A	B	kg
3-Phase 200V	LSLV0185H100-2	220(8.66)	193.8(7.63)	350(13.78)	331(13.03)	13(0.51)	223.2(8.79)	6(0.24)	6(0.24)	7.1
	LSLV0220H100-4	220(8.66)	193.8(7.63)	350(13.78)	331(13.03)	13(0.51)	223.2(8.79)	6(0.24)	6(0.24)	7.5
3-Phase 400V	LSLV0300H100-4	220(8.66)	193.8(7.63)	350(13.78)	331(13.03)	13(0.51)	223.2(8.79)	6(0.24)	6(0.24)	7.5

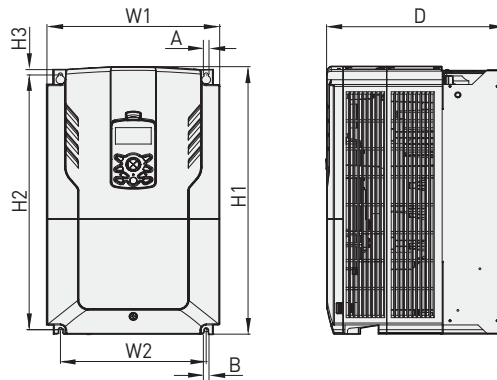

Unit: mm(inches)

Product (Model)		W1	W2	H1	H2	H3	D	A	B	kg
3-Phase 400V	LSLV0370H100-4	275(10.83)	232(9.13)	450(17.72)	428.5(16.87)	14(0.55)	284(11.18)	7(0.28)	7(0.28)	26

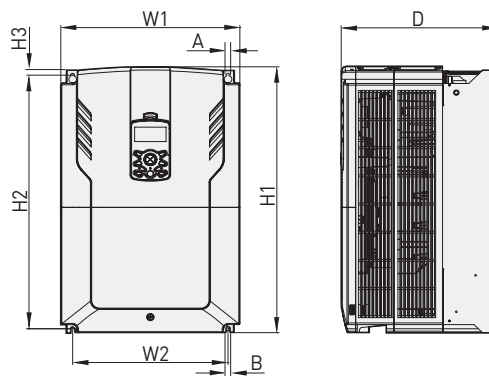

Unit: mm(inches)

Product (Model)		W1	W2	H1	H2	H3	D	A	B	kg
3-Phase 400V	LSLV0450H100-4	325(12.08)	282(11.10)	510(20.08)	486.5(19.15)	16(0.63)	284(11.18)	7(0.28)	7(0.28)	35
	LSLV0550H100-4	325(12.08)	282(11.10)	510(20.08)	486.5(19.15)	16(0.63)	284(11.18)	7(0.28)	7(0.28)	35

IP 20 Type

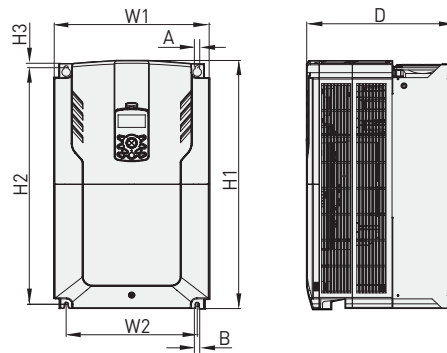

Unit:mm(inches)

Product (Model)		W1	W2	H1	H2	H3	D	A	B	kg
3-Phase 400V	LSLV0750H100-4	325(12.08)	275(10.83)	550(21.65)	524.5(20.65)	16(0.63)	309(12.80)	9(0.35)	9(0.35)	43
	LSLV0900H100-4	325(12.08)	275(10.83)	550(21.65)	524.5(20.65)	16(0.63)	309(12.80)	9(0.35)	9(0.35)	43

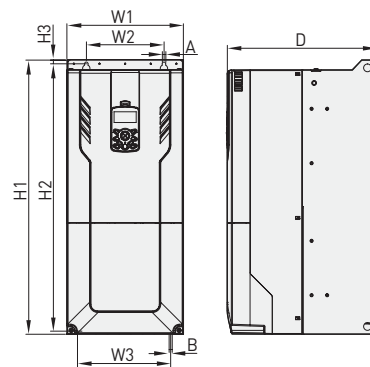

Unit:mm(inches)

Product (Model)		W1	W2	H1	H2	H3	D	A	B	kg
3-Phase 400V	LSLV1100H100-4	300(11.81)	200(7.87)	706(27.80)	688.5(27.11)	9.5(0.37)	386(15.20)	9(0.35)	9(0.35)	55.8
	LSLV1320H100-4	300(11.81)	200(7.87)	706(27.80)	688.5(27.11)	9.5(0.37)	386(15.20)	9(0.35)	9(0.35)	55.8
	LSLV1600H100-4	380(14.96)	300(11.81)	705(27.76)	685.5(26.99)	9.5(0.37)	396(15.59)	9(0.35)	9(0.35)	74.7
	LSLV1850H100-4	380(14.96)	300(11.81)	705(27.76)	685.5(26.99)	9.5(0.37)	396(15.59)	9(0.35)	9(0.35)	74.7

IP 00 Type

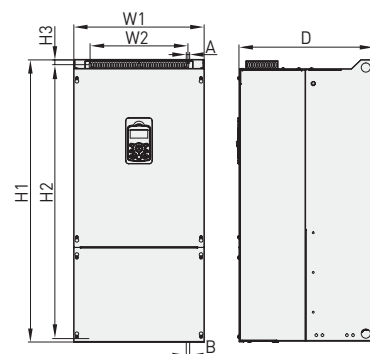

Unit:mm(inches)

Product (Model)		W1	W2	H1	H2	H3	D	A	B	kg
3-Phase 400V	LSLV2200H100-4	426 (16.77)	320(12.60)	922.3(36.31)	895.5(35.26)	15.5(0.61)	440(17.32)	11(0.43)	11(0.43)	120
	LSLV2500H100-4	426 (16.77)	320(12.60)	922.3(36.31)	895.5(35.26)	15.5(0.61)	440(17.32)	11(0.43)	11(0.43)	120
	LSLV3150H100-4	600(23.62)	420(16.54)	1000(39.37)	972(38.27)	15(0.59)	500(19.69)	14(0.55)	14(0.55)	185.5
	LSLV3550H100-4	600(23.62)	420(16.54)	1000(39.37)	972(38.27)	15(0.59)	500(19.69)	14(0.55)	14(0.55)	185.5
	LSLV4000H100-4	600(23.62)	420(16.54)	1000(39.37)	972(38.27)	15(0.59)	500(19.69)	14(0.55)	14(0.55)	185.5
	LSLV5000H100-4	776(30.55)	500(19.69)	1054(41.50)	1021(40.20)	20(0.79)	500(19.69)	14(0.55)	14(0.55)	265

Flange

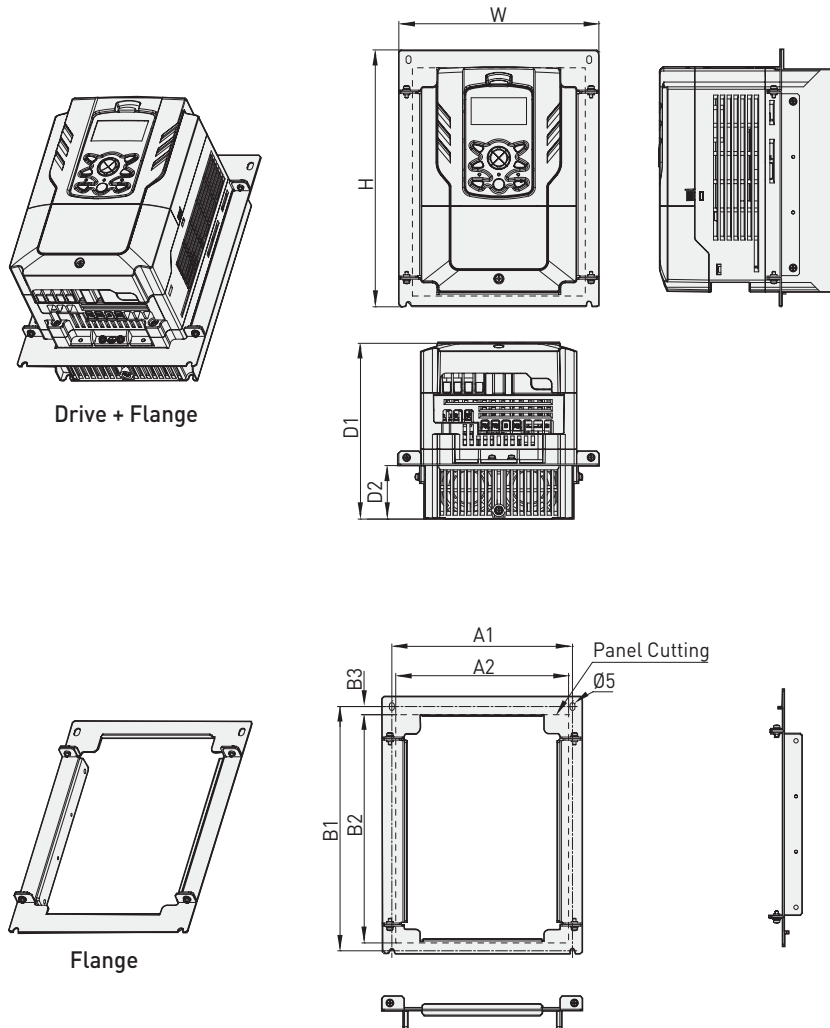

Unit:mm(inches)

Product (Model)		W	H	D1	D2	A1	A2	B1	B2	B3	kg
3-Phase 200V	LSLV0008H100-2	206(8.11)	264.5(10.41)	181(7.13)	55.1(2.17)	186(7.32)	178(7.01)	251.5(9.90)	235(9.25)	8.4(0.33)	3.7
	LSLV0015H100-2	206(8.11)	264.5(10.41)	181(7.13)	55.1(2.17)	186(7.32)	178(7.01)	251.5(9.90)	235(9.25)	8.4(0.33)	3.7
	LSLV0022H100-2	206(8.11)	264.5(10.41)	181(7.13)	55.1(2.17)	186(7.32)	178(7.01)	251.5(9.90)	235(9.25)	8.4(0.33)	3.7
	LSLV0037H100-2	206(8.11)	264.5(10.41)	181(7.13)	55.1(2.17)	186(7.32)	178(7.01)	251.5(9.90)	235(9.25)	8.4(0.33)	3.7
	LSLV0055H100-2	206(8.11)	264.5(10.41)	181(7.13)	55.1(2.17)	186(7.32)	178(7.01)	251.5(9.90)	235(9.25)	8.4(0.33)	3.7
	LSLV0075H100-2	206(8.11)	264.5(10.41)	181(7.13)	55.1(2.17)	186(7.32)	178(7.01)	251.5(9.90)	235(9.25)	8.4(0.33)	3.7
	LSLV0110H100-2	206(8.11)	264.5(10.41)	181(7.13)	55.1(2.17)	186(7.32)	178(7.01)	251.5(9.90)	235(9.25)	8.4(0.33)	3.7
3-Phase 400V	LSLV0008H100-4	206(8.11)	264.5(10.41)	181(7.13)	55.1(2.17)	186(7.32)	178(7.01)	251.5(9.90)	235(9.25)	8.4(0.33)	3.7
	LSLV0015H100-4	206(8.11)	264.5(10.41)	181(7.13)	55.1(2.17)	186(7.32)	178(7.01)	251.5(9.90)	235(9.25)	8.4(0.33)	3.7
	LSLV0022H100-4	206(8.11)	264.5(10.41)	181(7.13)	55.1(2.17)	186(7.32)	178(7.01)	251.5(9.90)	235(9.25)	8.4(0.33)	3.7
	LSLV0037H100-4	206(8.11)	264.5(10.41)	181(7.13)	55.1(2.17)	186(7.32)	178(7.01)	251.5(9.90)	235(9.25)	8.4(0.33)	3.7
	LSLV0055H100-4	206(8.11)	264.5(10.41)	181(7.13)	55.1(2.17)	186(7.32)	178(7.01)	251.5(9.90)	235(9.25)	8.4(0.33)	3.7
	LSLV0075H100-4	206(8.11)	264.5(10.41)	181(7.13)	55.1(2.17)	186(7.32)	178(7.01)	251.5(9.90)	235(9.25)	8.4(0.33)	3.7
	LSLV0110H100-4	206(8.11)	264.5(10.41)	181(7.13)	55.1(2.17)	186(7.32)	178(7.01)	251.5(9.90)	235(9.25)	8.4(0.33)	3.7

Flange

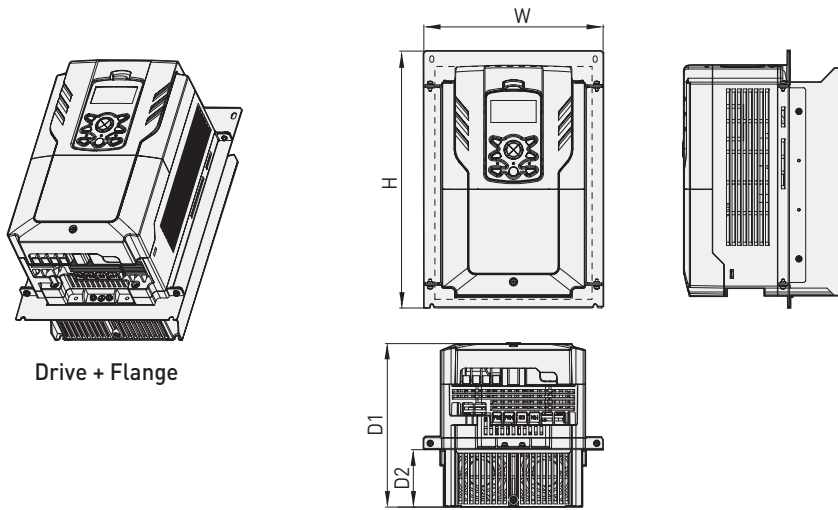

Drive + Flange

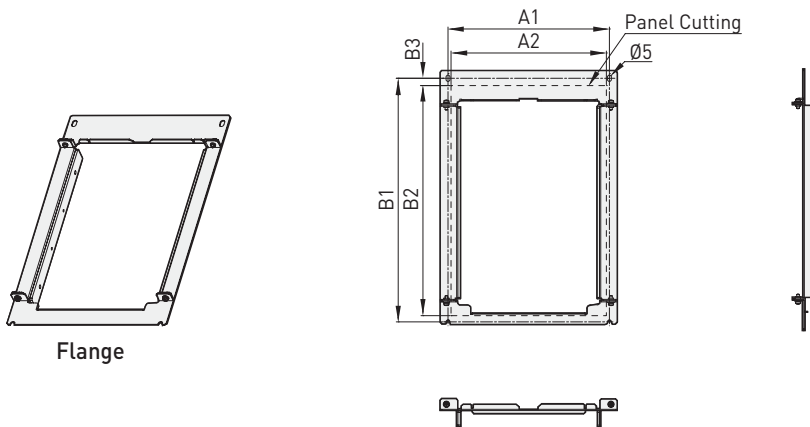

Flange

Unit:mm(inches)

Product (Model)		W	H	D1	D2	A1	A2	B1	B2	B3	kg
3-Phase 200V	LSLV0150H100-2	225.2(8.87)	322.7(12.70)	205.3(8.08)	72.1(2.84)	205.2(8.08)	197.5(7.78)	309.7(12.19)	292.5(11.52)	9.3(0.34)	5.2
3-Phase 400V	LSLV0150H100-4	225.2(8.87)	322.7(12.70)	205.3(8.08)	72.1(2.84)	205.2(8.08)	197.5(7.78)	309.7(12.19)	292.5(11.52)	9.3(0.34)	5.2
	LSLV0185H100-4	225.2(8.87)	322.7(12.70)	205.3(8.08)	72.1(2.84)	205.2(8.08)	197.5(7.78)	309.7(12.19)	292.5(11.52)	9.3(0.34)	5.4

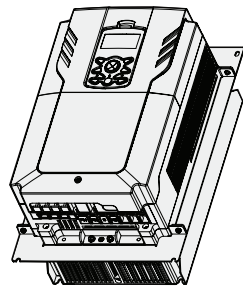

Drive + Flange

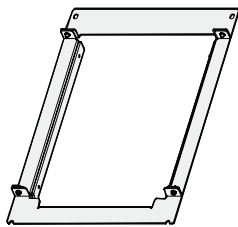
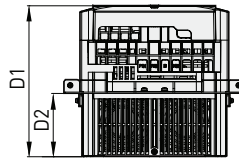
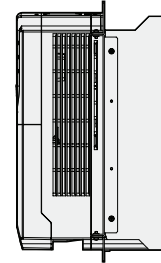
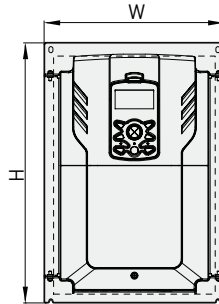

Flange

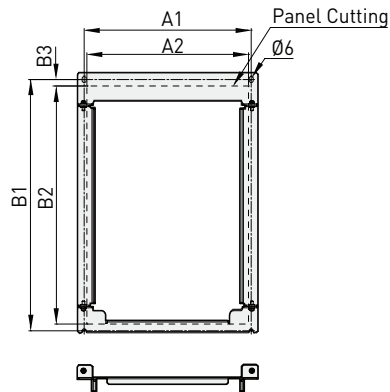

Unit:mm(inches)

Product (Model)		W	H	D1	D2	A1	A2	B1	B2	B3	kg
3-Phase 200V	LSLV0185H100-2	267(10.51)	384.5(15.14)	223.2(8.79)	93.6(3.69)	247(9.72)	239(9.41)	371.5(14.63)	352(13.86)	9.5(0.37)	8.3
	LSLV0220H100-4	267(10.51)	384.5(15.14)	223.2(8.79)	93.6(3.69)	247(9.72)	239(9.41)	371.5(14.63)	352(13.86)	9.5(0.37)	8.3
3-Phase 400V	LSLV0300H100-4	267(10.51)	384.5(15.14)	223.2(8.79)	93.6(3.69)	247(9.72)	239(9.41)	371.5(14.63)	352(13.86)	9.5(0.37)	8.3

Flange

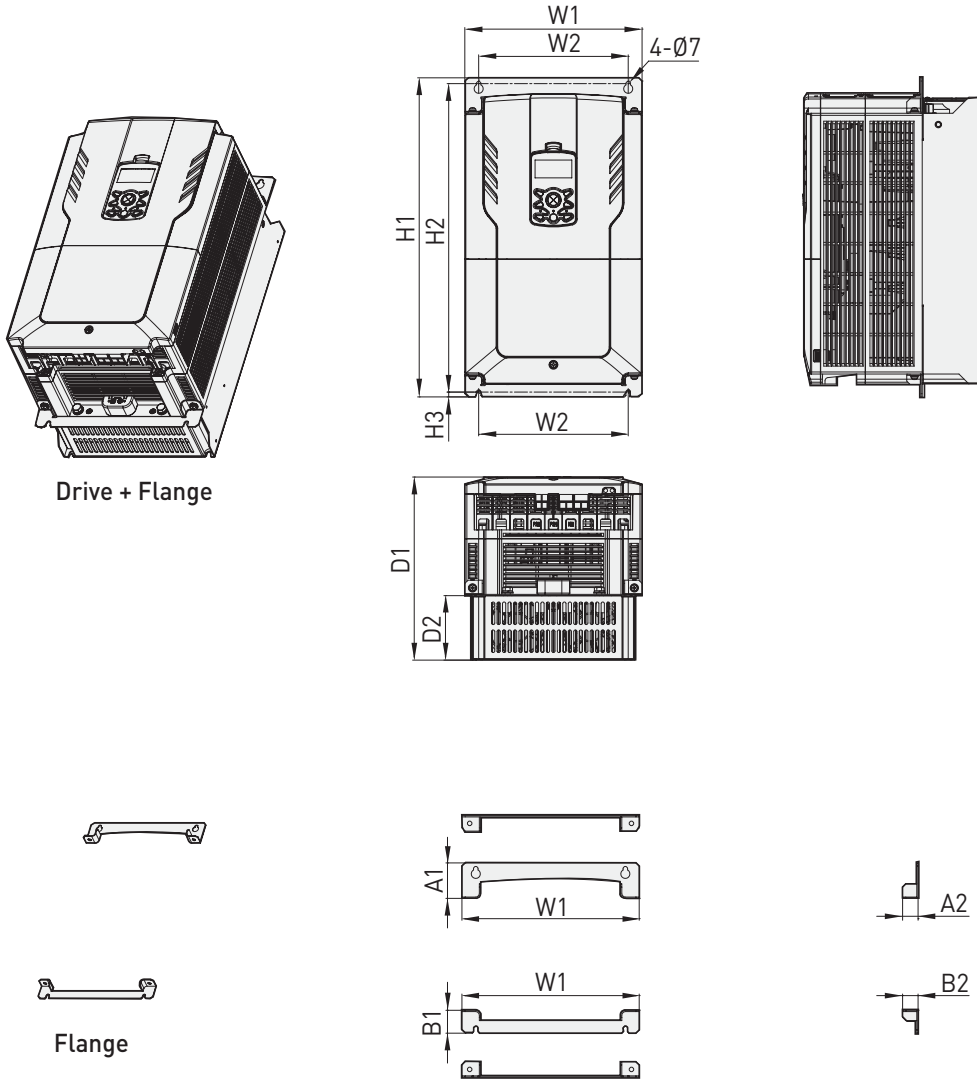

Drive + Flange

Flange

Unit:mm(inches)

Product (Model)	W1	W2	H1	H2	H3	D1	D2	A1	A2	B1	B2	kg
3-Phase 400V LSLV0370H100-4	275 (10.83)	232 (9.13)	495 (19.49)	478.5 (18.84)	7.5 (0.30)	284 (11.18)	100 (3.94)	55 (2.17)	24 (0.98)	35.5 (1.40)	24 (0.98)	26.4

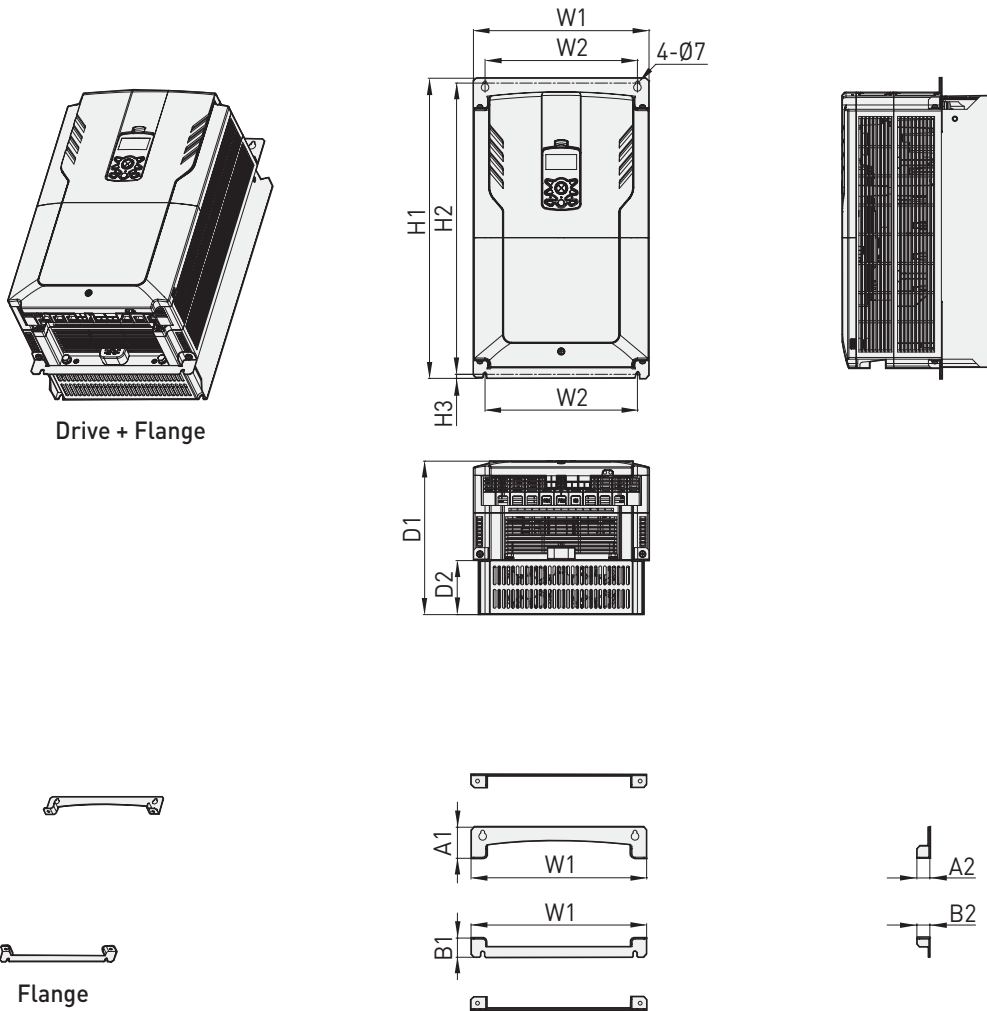

Unit:mm(inches)

Product (Model)		W1	W2	H1	H2	H3	D1	D2	A1	A2	B1	B2	kg
3-Phase 400V	LSLV0450H100-4	325 (12.80)	282 (11.10)	555.5 (21.87)	539 (21.22)	7.5 (0.30)	284 (11.18)	100 (3.94)	57.5 (2.26)	24 (0.94)	35.5 (1.40)	24 (0.94)	35.4
	LSLV0550H100-4	325 (12.80)	282 (11.10)	555.5 (21.87)	539 (21.22)	7.5 (0.30)	284 (11.18)	100 (3.94)	57.5 (2.26)	24 (0.94)	35.5 (1.40)	24 (0.94)	35.4

Flange

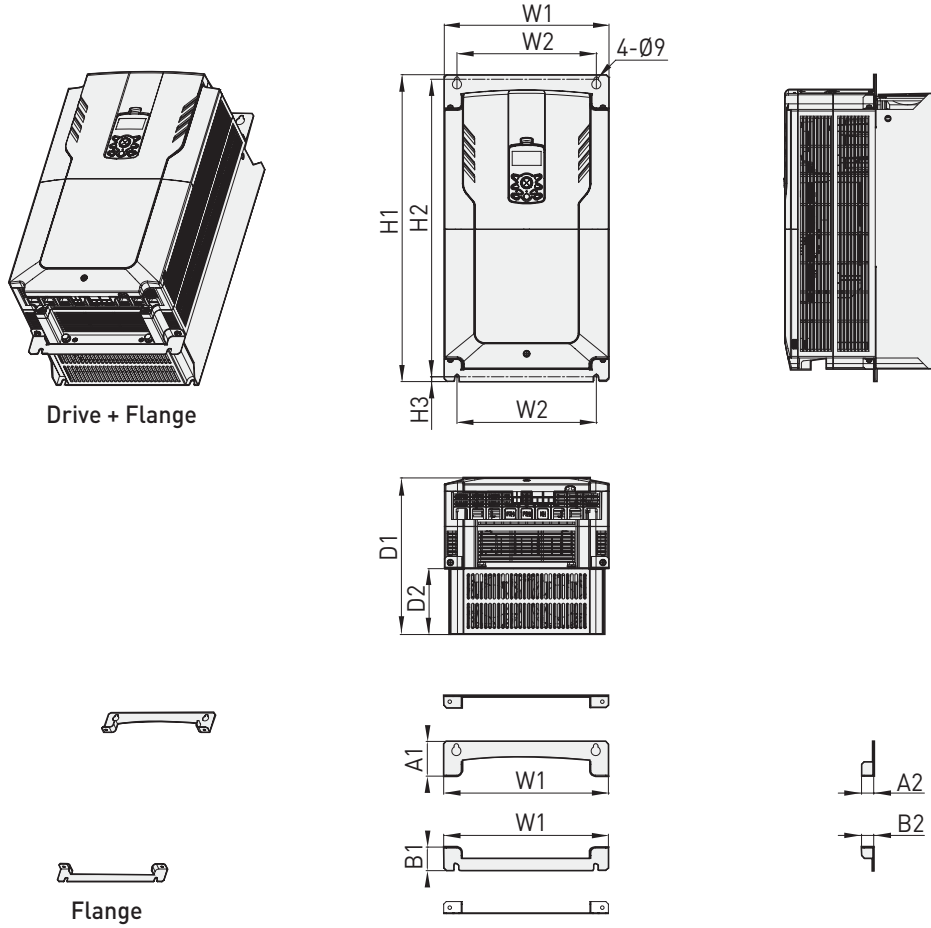

Unit:mm(inches)

Product (Model)		W1	W2	H1	H2	H3	D1	D2	A1	A2	B1	B2	kg
3-Phase 400V	LSLV0750H100-4	325 (12.80)	275 (10.83)	605.5 (23.84)	587 (23.11)	9.5 (0.37)	309 (12.17)	130 (5.12)	68.5 (2.69)	24 (0.94)	46.5 (1.83)	24 (0.94)	43.5
	LSLV0900H100-4	325 (12.80)	275 (10.83)	605.5 (23.84)	587 (23.11)	9.5 (0.37)	309 (12.17)	130 (5.12)	68.5 (2.69)	24 (0.94)	46.5 (1.83)	24 (0.94)	43.5

Conduit

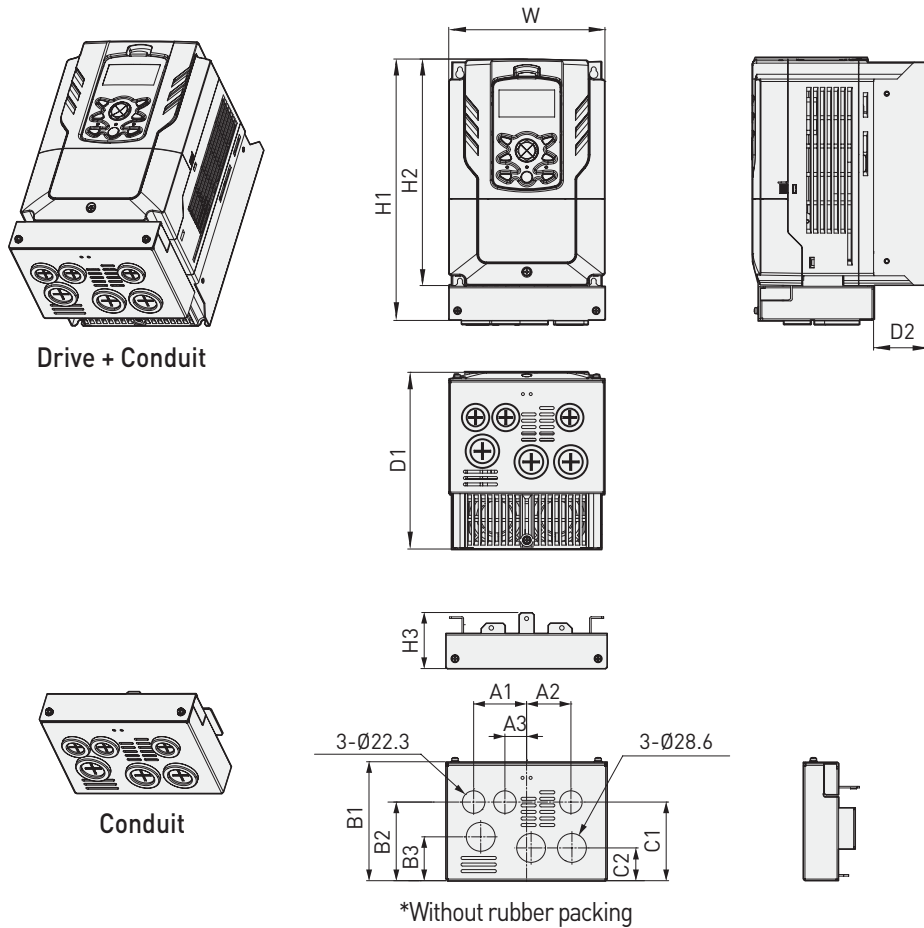

Unit: mm(inches)

Product (Model)		W	H1	H2	H3	D1	D2	A1	A2	A3	B1	B2	B3	C1	C2	kg
3-Phase 200V	LSLV0008H100-2	160(6.30)	267.8(10.54)	232(9.13)	55.6(2.19)	181(7.13)	56.7(2.23)	52.5(2.07)	44(1.73)	21.5(0.85)	117.6(4.63)	78(3.07)	43.5(1.71)	78(3.07)	32.5(1.28)	3.9
	LSLV0015H100-2	160(6.30)	267.8(10.54)	232(9.13)	55.6(2.19)	181(7.13)	56.7(2.23)	52.5(2.07)	44(1.73)	21.5(0.85)	117.6(4.63)	78(3.07)	43.5(1.71)	78(3.07)	32.5(1.28)	3.9
	LSLV0022H100-2	160(6.30)	267.8(10.54)	232(9.13)	55.6(2.19)	181(7.13)	56.7(2.23)	52.5(2.07)	44(1.73)	21.5(0.85)	117.6(4.63)	78(3.07)	43.5(1.71)	78(3.07)	32.5(1.28)	3.9
	LSLV0037H100-2	160(6.30)	267.8(10.54)	232(9.13)	55.6(2.19)	181(7.13)	56.7(2.23)	52.5(2.07)	44(1.73)	21.5(0.85)	117.6(4.63)	78(3.07)	43.5(1.71)	78(3.07)	32.5(1.28)	3.9
	LSLV0055H100-2	160(6.30)	267.8(10.54)	232(9.13)	55.6(2.19)	181(7.13)	56.7(2.23)	52.5(2.07)	44(1.73)	21.5(0.85)	117.6(4.63)	78(3.07)	43.5(1.71)	78(3.07)	32.5(1.28)	3.9
	LSLV0075H100-2	160(6.30)	267.8(10.54)	232(9.13)	55.6(2.19)	181(7.13)	56.7(2.23)	52.5(2.07)	44(1.73)	21.5(0.85)	117.6(4.63)	78(3.07)	43.5(1.71)	78(3.07)	32.5(1.28)	3.9
	LSLV0110H100-2	160(6.30)	267.8(10.54)	232(9.13)	55.6(2.19)	181(7.13)	56.7(2.23)	52.5(2.07)	44(1.73)	21.5(0.85)	117.6(4.63)	78(3.07)	43.5(1.71)	78(3.07)	32.5(1.28)	3.9
3-Phase 400V	LSLV0008H100-4	160(6.30)	267.8(10.54)	232(9.13)	55.6(2.19)	181(7.13)	56.7(2.23)	52.5(2.07)	44(1.73)	21.5(0.85)	117.6(4.63)	78(3.07)	43.5(1.71)	78(3.07)	32.5(1.28)	3.9
	LSLV0015H100-4	160(6.30)	267.8(10.54)	232(9.13)	55.6(2.19)	181(7.13)	56.7(2.23)	52.5(2.07)	44(1.73)	21.5(0.85)	117.6(4.63)	78(3.07)	43.5(1.71)	78(3.07)	32.5(1.28)	3.9
	LSLV0022H100-4	160(6.30)	267.8(10.54)	232(9.13)	55.6(2.19)	181(7.13)	56.7(2.23)	52.5(2.07)	44(1.73)	21.5(0.85)	117.6(4.63)	78(3.07)	43.5(1.71)	78(3.07)	32.5(1.28)	3.9
	LSLV0037H100-4	160(6.30)	267.8(10.54)	232(9.13)	55.6(2.19)	181(7.13)	56.7(2.23)	52.5(2.07)	44(1.73)	21.5(0.85)	117.6(4.63)	78(3.07)	43.5(1.71)	78(3.07)	32.5(1.28)	3.9
	LSLV0055H100-4	160(6.30)	267.8(10.54)	232(9.13)	55.6(2.19)	181(7.13)	56.7(2.23)	52.5(2.07)	44(1.73)	21.5(0.85)	117.6(4.63)	78(3.07)	43.5(1.71)	78(3.07)	32.5(1.28)	3.9
	LSLV0075H100-4	160(6.30)	267.8(10.54)	232(9.13)	55.6(2.19)	181(7.13)	56.7(2.23)	52.5(2.07)	44(1.73)	21.5(0.85)	117.6(4.63)	78(3.07)	43.5(1.71)	78(3.07)	32.5(1.28)	3.9
	LSLV0110H100-4	160(6.30)	267.8(10.54)	232(9.13)	55.6(2.19)	181(7.13)	56.7(2.23)	52.5(2.07)	44(1.73)	21.5(0.85)	117.6(4.63)	78(3.07)	43.5(1.71)	78(3.07)	32.5(1.28)	4.0

Conduit

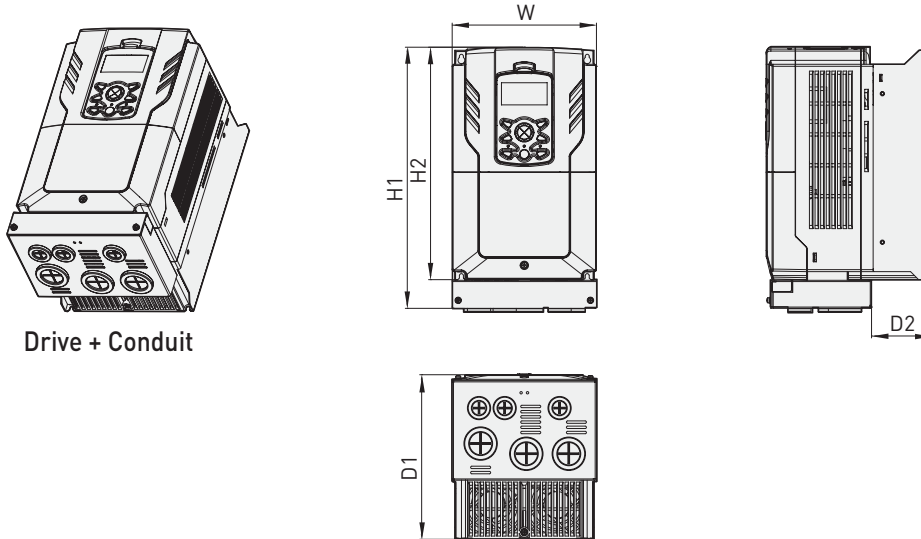

Drive + Conduit

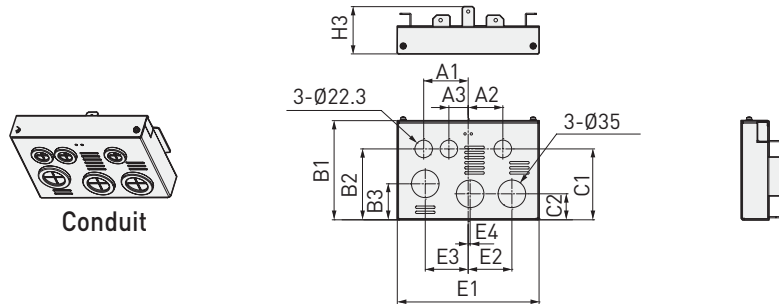

Conduit

*Without rubber packing

Unit:mm(inches)

Product (Model)		W	H1	H2	H3	D1	D2	A1	A2	A3	B1	B2	B3	C1	C2	E1	E2	E3	E4	kg
3-Phase 200V	LSLV0150H100-2	180 (7.09)	325.8 (12.83)	290 (11.42)	60 (2.36)	205.3 (8.08)	73.7 (2.90)	56.5 (2.22)	44 (1.73)	24.5 (0.96)	125.9 (4.96)	90 (3.54)	45.7 (1.80)	90 (3.54)	33 (1.30)	180 (7.09)	55.5 (2.19)	54.5 (2.15)	2.5 (0.10)	5.2
	LSLV0150H100-4	180 (7.09)	325.8 (12.83)	290 (11.42)	60 (2.36)	205.3 (8.08)	73.7 (2.90)	56.5 (2.22)	44 (1.73)	24.5 (0.96)	125.9 (4.96)	90 (3.54)	45.7 (1.80)	90 (3.54)	33 (1.30)	180 (7.09)	55.5 (2.19)	54.5 (2.15)	2.5 (0.10)	5.2
3-Phase 400V	LSLV0185H100-4	180 (7.09)	325.8 (12.83)	290 (11.42)	60 (2.36)	205.3 (8.08)	73.7 (2.90)	56.5 (2.22)	44 (1.73)	24.5 (0.96)	125.9 (4.96)	90 (3.54)	45.7 (1.80)	90 (3.54)	33 (1.30)	180 (7.09)	55.5 (2.19)	54.5 (2.15)	2.5 (0.10)	5.4

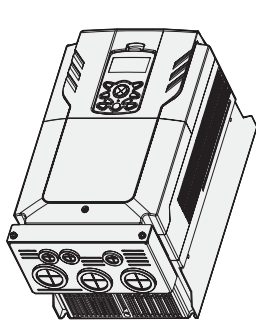

Drive + Conduit

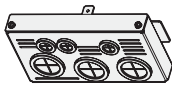
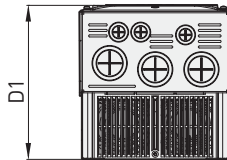
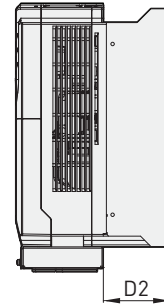
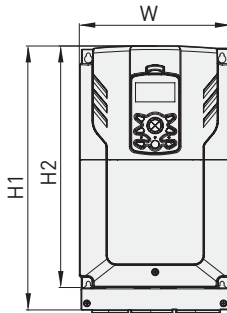

Conduit

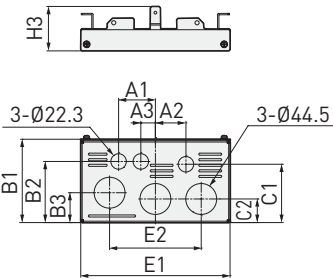

*Without rubber packing

Unit: mm(inches)

Product (Model)		W	H1	H2	H3	D1	D2	A1	A2	A3	B1	B2	B3	C1	C2	E1	E2	kg
3-Phase 200V	LSLV0185H100-2	220 (8.66)	382.5 (15.06)	350 (13.78)	64 (2.52)	223.2 (8.79)	96.4 (3.80)	53 (2.09)	44 (1.73)	21 (0.83)	120 (4.72)	88 (3.46)	43 (1.69)	84 (3.31)	34 (1.34)	215 (8.46)	132 (5.20)	5.2
	LSLV0220H100-4	220 (8.66)	382.5 (15.06)	350 (13.78)	64 (2.52)	223.2 (8.79)	96.4 (3.80)	53 (2.09)	44 (1.73)	21 (0.83)	120 (4.72)	88 (3.46)	43 (1.69)	84 (3.31)	34 (1.34)	215 (8.46)	132 (5.20)	5.2
3-Phase 400V	LSLV0300H100-4	220 (8.66)	382.5 (15.06)	350 (13.78)	64 (2.52)	223.2 (8.79)	96.4 (3.80)	53 (2.09)	44 (1.73)	21 (0.83)	120 (4.72)	88 (3.46)	43 (1.69)	84 (3.31)	34 (1.34)	215 (8.46)	132 (5.20)	5.4

Conduit

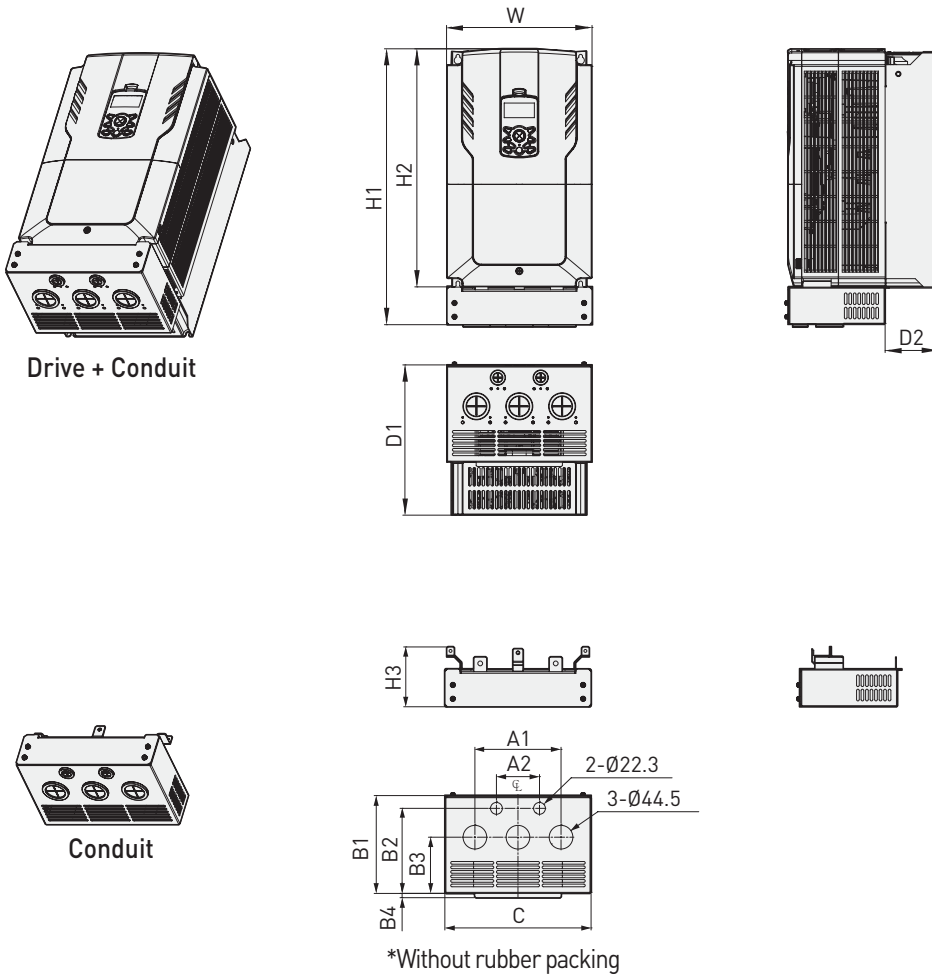

Unit:mm(inches)

Product (Model)	W	H1	H2	H3	D1	D2	A1	A2	B1	B2	B3	B4	C	kg
3-Phase 400V LSLV0370H100-4	275 (10.83)	521.5 (20.53)	450 (17.72)	112.5 (4.43)	284 (11.18)	100 (3.94)	162 (6.38)	81 (3.19)	184 (7.24)	160 (6.30)	105.8 (4.17)	8 (0.31)	275 (10.83)	28.7

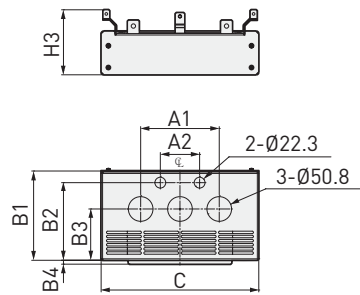
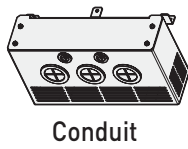
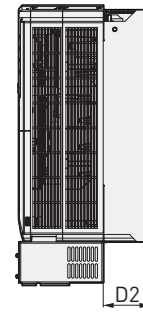
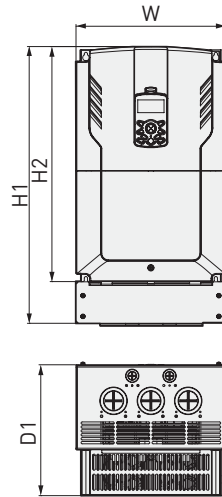
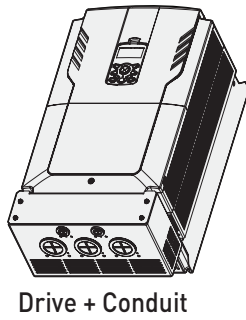

*Without rubber packing

Unit:mm(inches)

Product (Model)		W	H1	H2	H3	D1	D2	A1	A2	B1	B2	B3	B4	C	kg
3-Phase 400V	LSLV0450H100-4	325 (12.80)	600.5 (23.64)	510 (20.08)	134 (5.28)	284 (11.18)	100 (3.94)	162 (6.38)	81 (3.19)	184 (7.24)	160 (6.30)	105.8 (4.17)	8 (0.31)	325 (12.80)	38.4
	LSLV0550H100-4	325 (12.80)	600.5 (23.64)	510 (20.08)	134 (5.28)	284 (11.18)	100 (3.94)	162 (6.38)	81 (3.19)	184 (7.24)	160 (6.30)	105.8 (4.17)	8 (0.31)	325 (12.80)	38.4

Conduit

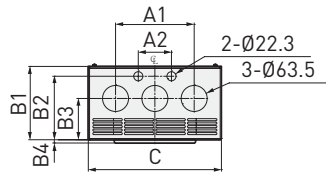
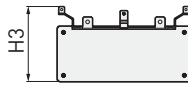
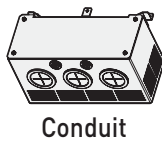
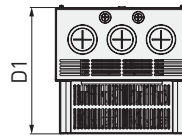
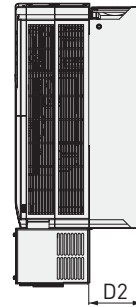
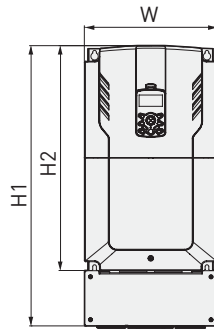
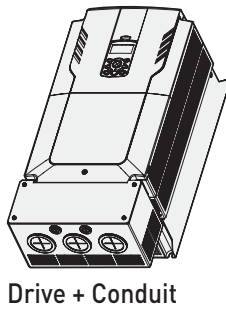

*Without rubber packing

Unit:mm(inches)

Product (Model)		W	H1	H2	H3	D1	D2	A1	A2	B1	B2	B3	B4	C	kg
3-Phase 400V	LSLV0750H100-4	325 (12.80)	685.5 (26.99)	550 (21.65)	183 (7.20)	309 (12.17)	130 (5.12)	192 (7.56)	81 (3.19)	179 (7.05)	155 (6.10)	100.75 (3.97)	8 (0.31)	325 (12.80)	47.2
	LSLV0900H100-4	325 (12.80)	685.5 (26.99)	550 (21.65)	183 (7.20)	309 (12.17)	130 (5.12)	192 (7.56)	81 (3.19)	179 (7.05)	155 (6.10)	100.75 (3.97)	8 (0.31)	325 (12.80)	47.2

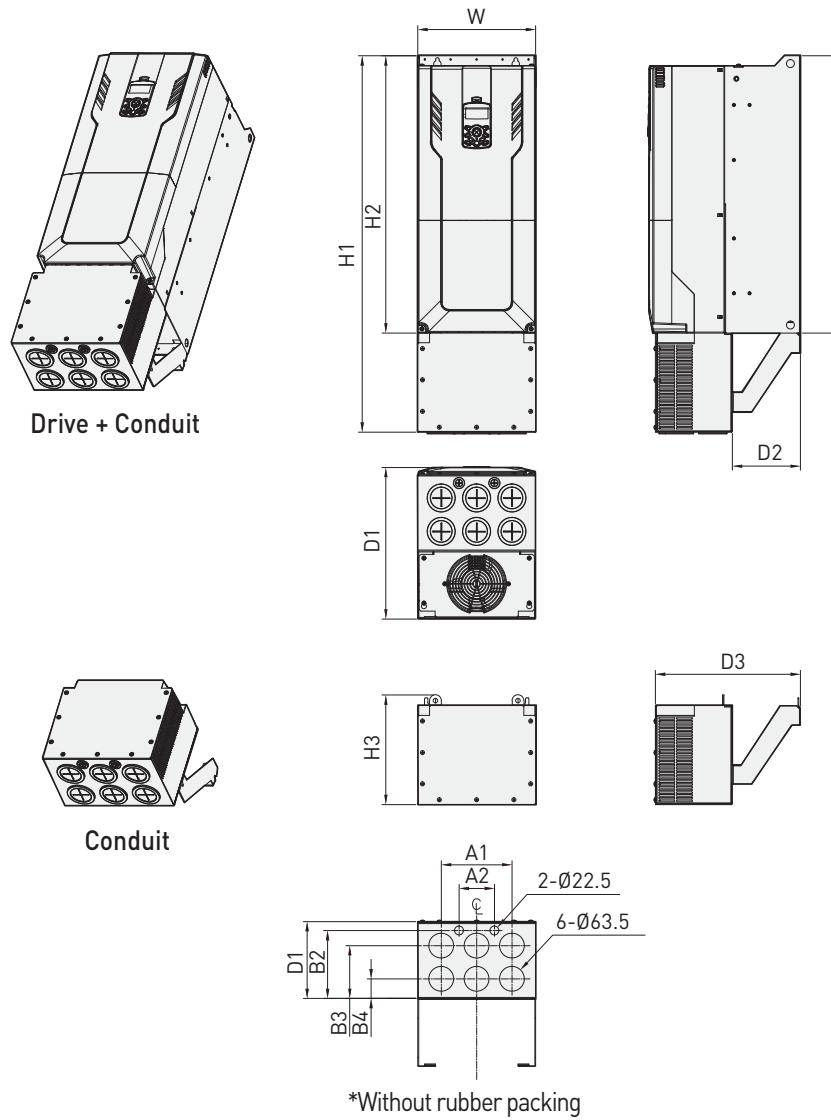

Unit:mm(inches)

Product (Model)		W	H1	H2	H3	D1	D2	D3	A1	A2	B1	B2	B3	B4	kg
3-Phase 400V	LSLV1100H100-4	300 (11.81)	958.5 (37.74)	706 (27.80)	279.5 (11.00)	386 (15.20)	173 (6.81)	369 (14.53)	180 (7.09)	90 (3.54)	196 (7.72)	172.25 (6.78)	134.75 (5.31)	49.75 (1.96)	62.31
	LSLV1320H100-4	300 (11.81)	958.5 (37.74)	706 (27.80)	279.5 (11.00)	386 (15.20)	173 (6.81)	369 (14.53)	180 (7.09)	90 (3.54)	196 (7.72)	172.25 (6.78)	134.75 (5.31)	49.75 (1.96)	62.31

Conduit

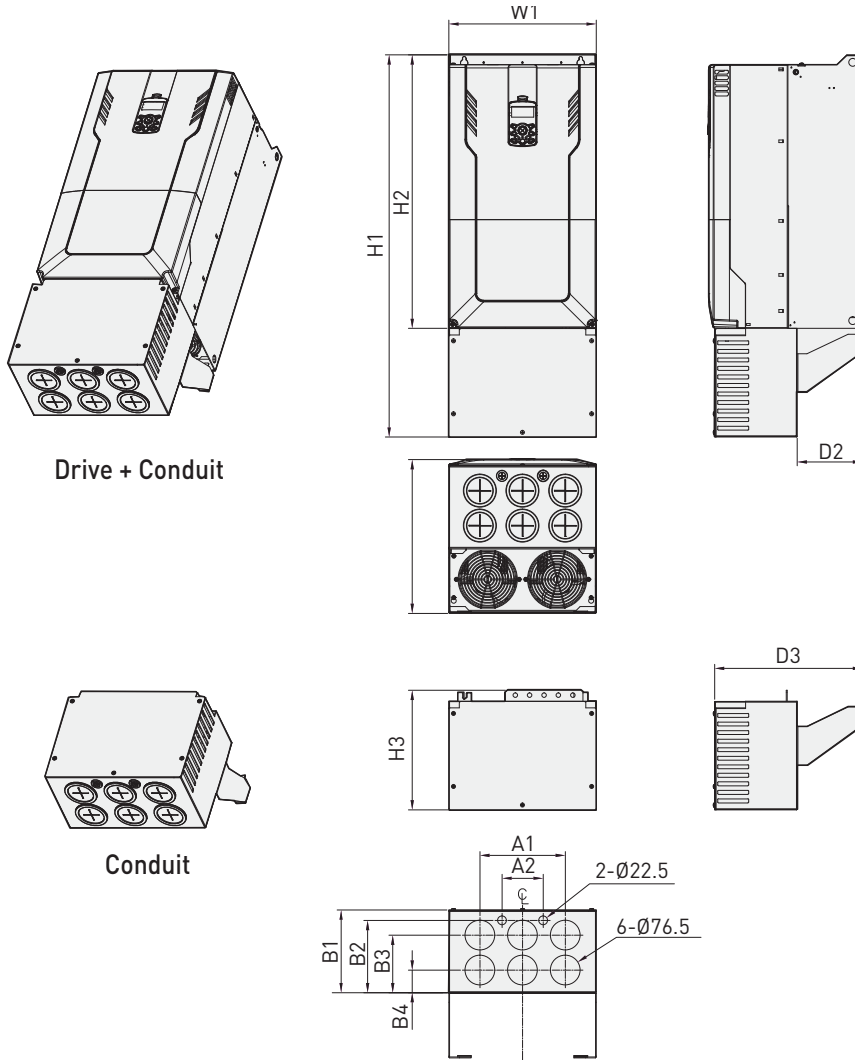

*Without rubber packing

Unit:mm(inches)

Product (Model)		W	H1	H2	H3	D1	D2	D3	A1	A2	B1	B2	B3	B4	kg
3-Phase 400V	LSLV1600H100-4	380 (14.96)	985 (38.78)	705 (27.76)	308 (12.13)	396 (15.59)	168 (6.61)	381 (15.00)	220 (8.66)	106 (4.17)	213 (8.39)	186 (7.32)	148 (5.83)	58 (2.28)	81.24
	LSLV1850H100-4	380 (14.96)	985 (38.78)	705 (27.76)	308 (12.13)	396 (15.59)	168 (6.61)	381 (15.00)	220 (8.66)	106 (4.17)	213 (8.39)	186 (7.32)	148 (5.83)	58 (2.28)	81.24

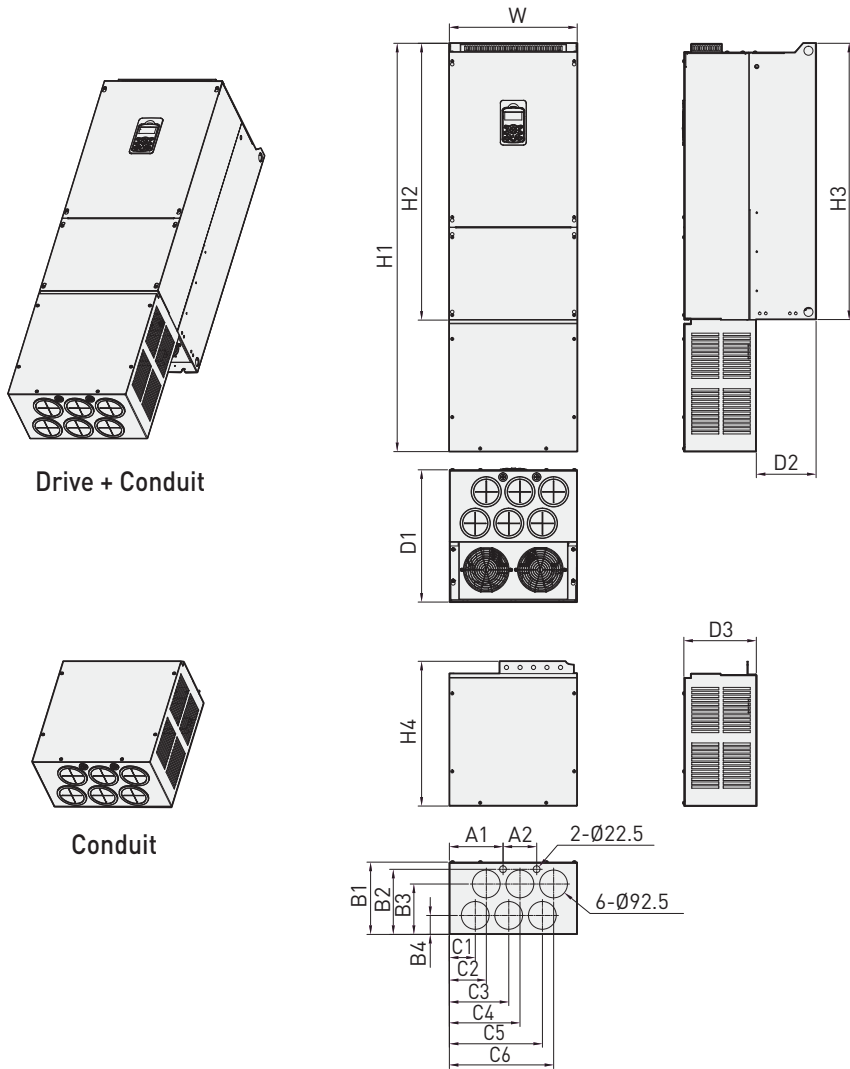

*Without rubber packing

Unit: mm(inches)

Product (Model)		W	H1	H2	H3	H4	D1	D2	D3	A1	A2	
3-Phase 400V	LSLV2200H100-4	426 (16.77)	1360.3 (53.56)	922.3 (36.31)	920 (36.22)	482 (18.98)	440 (17.32)	199 (7.83)	241 (9.49)	179 (7.05)	112 (4.41)	
	LSLV2500H100-4	426 (16.77)	1360.3 (53.56)	922.3 (36.31)	920 (36.22)	482 (18.98)	440 (17.32)	199 (7.83)	241 (9.49)	179 (7.05)	112 (4.41)	
Product (Model)		B1	B2	B3	B4	C1	C2	C3	C4	C5	C6	kg
3-Phase 400V	LSLV2200H100-4	241 (9.49)	217 (8.54)	168 (6.61)	63 (2.48)	86 (3.39)	123 (4.84)	198 (7.80)	235 (9.25)	310 (12.20)	347 (13.66)	130.54
	LSLV2500H100-4	241 (9.49)	217 (8.54)	168 (6.61)	63 (2.48)	86 (3.39)	123 (4.84)	198 (7.80)	235 (9.25)	310 (12.20)	347 (13.66)	130.54

Conduit

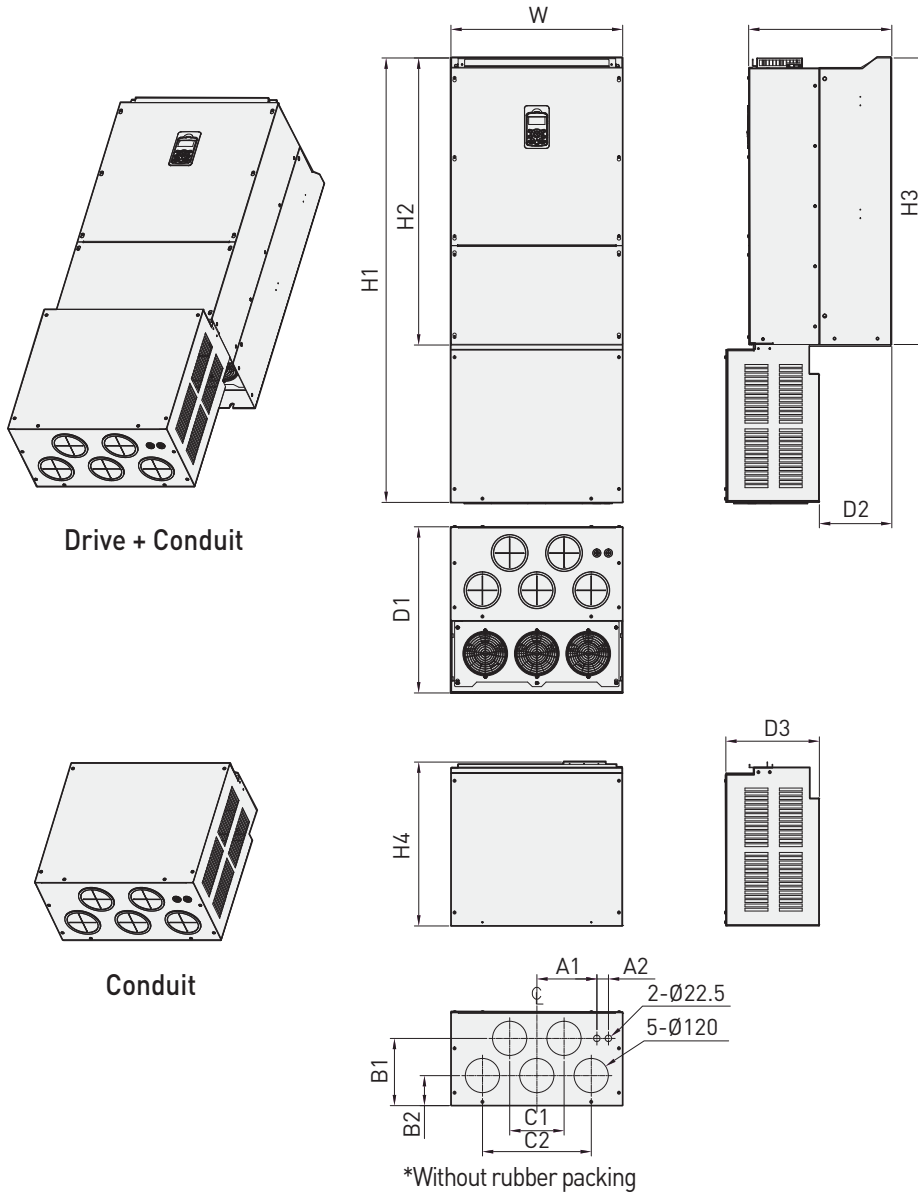

Unit:mm(inches)

Product (Model)	W	H1	H2	H3	H4	D1	D2	D3	A1	A2	B1	B2	C1	C2	kg	
3-Phase 400V	LSLV3150H100-4	600 (23.62)	1552 (61.10)	1002 (39.45)	1000 (39.37)	572.5 (22.54)	580 (22.83)	253 (9.96)	327 (12.87)	210 (8.27)	40 (1.57)	235 (9.25)	105 (4.13)	190 (7.48)	380 (14.96)	205.72
	LSLV3550H100-4	600 (23.62)	1552 (61.10)	1002 (39.45)	1000 (39.37)	572.5 (22.54)	580 (22.83)	253 (9.96)	327 (12.87)	210 (8.27)	40 (1.57)	235 (9.25)	105 (4.13)	190 (7.48)	380 (14.96)	205.72
	LSLV4000H100-4	600 (23.62)	1552 (61.10)	1002 (39.45)	1000 (39.37)	572.5 (22.54)	580 (22.83)	253 (9.96)	327 (12.87)	210 (8.27)	40 (1.57)	235 (9.25)	105 (4.13)	190 (7.48)	380 (14.96)	205.72

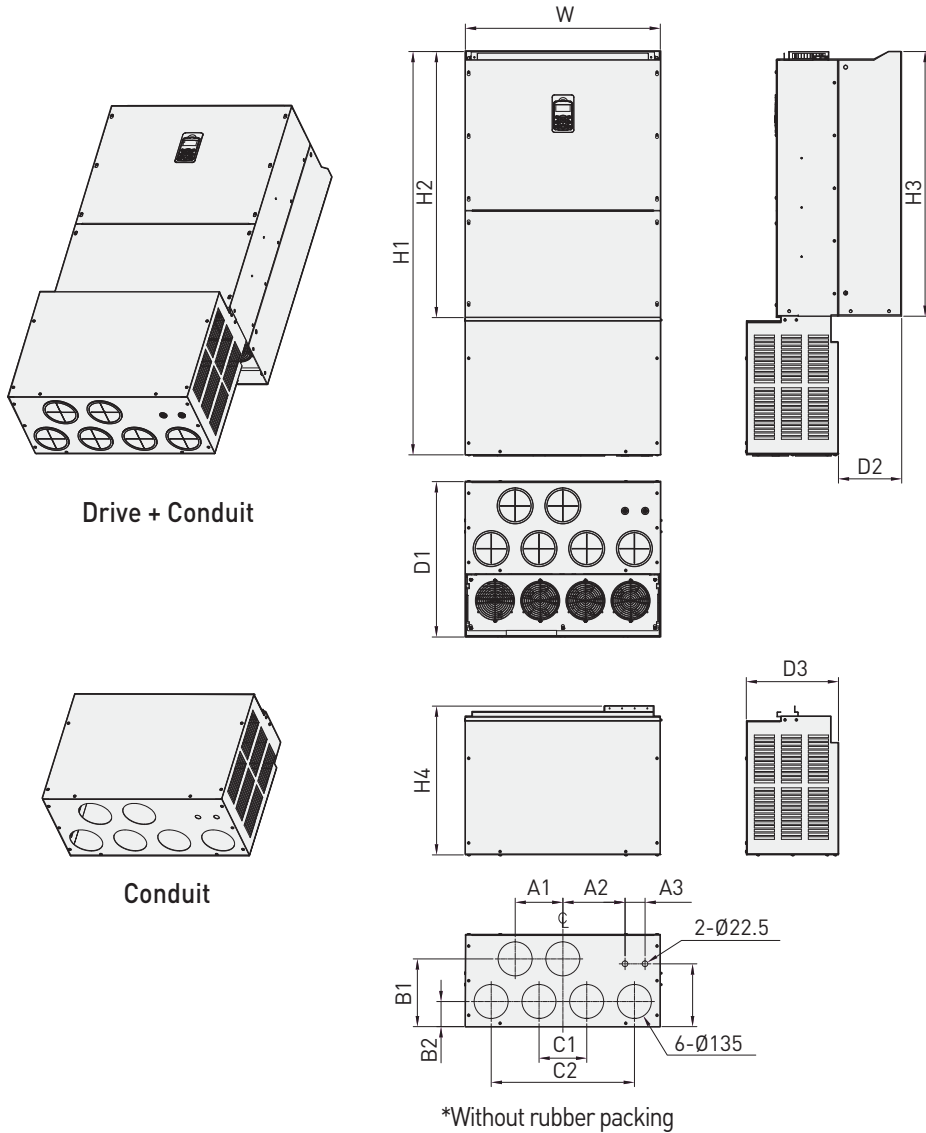

Unit: mm(inches)

Product (Model)		W	H1	H2	H3	H4	D1	D2	D3	A1	A2	A3	B1	B2	B3	C1	C2	kg
3-Phase 400V	LSLV5000H100-4	776 (30.55)	1606 (63.23)	1059.5 (41.71)	1054 (41.50)	592.4 (23.32)	618.5 (24.35)	251.5 (9.90)	367 (14.45)	190 (7.48)	247.5 (9.74)	80 (3.15)	270 (10.63)	100 (3.94)	250 (9.84)	190 (7.48)	570 (22.44)	290.91

Fuse/Reactor Specifications

Producto (kW)		AC Input Fuse		AC Reactor		DC Reactor	
		Current (A)	Voltage (V)	Inductance (mH)	Current (A)	Inductance (mH)	Current (A)
3-Phase 200V	0.75	10	600	2.02	5	4.04	5
	1.5	10		1.26	8	2.53	8
	2.2	15		0.78	12	1.68	12
	3.7	20		0.59	16	1.26	16
	5.5	50		0.43	24	0.93	25
	7.5	63		0.31	33	0.73	32
	11	80		0.22	46	0.53	50
	15	100		0.16	62	0.32	62
	18.5	125		0.13	77	0.29	80
3-Phase 400V	0.75	10	600	8.09	25	16.17	3
	1.5	10		5.05	4	10.11	4
	2.2	15		3.37	6	6.74	6
	3.7	20		2.25	9	5.05	8
	5.5	32		1.56	13	3.56	13
	7.5	35		1.16	17	2.53	18
	11	50		0.76	27	1.64	26
	15	63		0.61	33	1.42	33
	18.5	70		0.48	43	0.98	42
	22	100		0.40	51	0.88	50
	30	125		0.29	69	0.59	68
	37			0.29	69	Built In	
	45	160		0.24	85		
	55	200		0.20	100		
	75	250		0.15	134		
	90	350		0.13	160		
	110	350		0.1	217		
	132	400		0.08	257		
	160	450		0.07	318		
	185	550		0.06	362		
	220	630		0.05	423		
	250	700		0.05	474		
	315	800		0.04	604		
355	1000	0.03	673				
400	1100	0.03	759				
500	1250	0.03	948				